

V1-1

Steering

Center articulation pivot means steering is far smoother than with any skid steer or front wheel steer system. Tight corners are a breeze. Also bucket can be swung left and right by articulating when stopped. Tire wear is down, user fatigue is down, maneuverability is up.

Dimensions

Big walk-thru space for driver builds confidence. The good side vision is valuable in tight spaces. Small overall vehicle size improves access to narrow sites. Ideal for gardening, farming - in fact a wide variety of uses.

Engine

Power unit is compact and powerful. Automatic air bleed system means an end to "air in fuel line" worries. Extremely low noise level of 70dB (A) at 7m is achieved by thorough attention to detail. The use of a non-metal bonnet and efficient sound absorbing materials, are good not for only the operator, but for the neighbors as well.

Shift & Load

Automatic HST transmission means no clutch worries. Operation is smooth across the full range of forward and reverse movements. Bucket reach and dump angles allow loading of 2 tonne trucks with ease. Bucket leveling system makes the novice look like a pro.

Seat

Seamless seat prevents water leaks and tears. Provides long and trouble-free life.

Dimensions (Unit: mm)

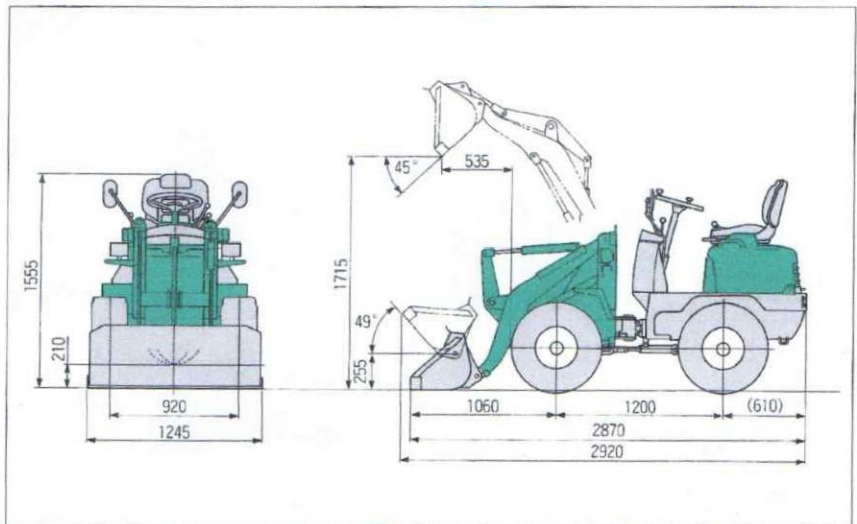

Specifications

MODEL		V1-1
ENGINE		
Type	3-cyl, water-cooled diesel	
Model	3TN66L-UKB	
Out put	hp/rpm(kw)	12.5/2600(9.2)
Displacement	cc	658
PERFORMANCE		
Std. bucket capacity	m ³ (cu.ft)	0.16(0.21)
Operating load	kg(lds)	270(595)
Tipping load	(straight) kg(lds)	580(1279)
	(full turn) kg(lds)	540(1190)
Bucket force	kg(lds)	820(1808)
Dumping clearance	mm(in)	1715(67.5)
Traveling speed F/R	km/h(mph)	10.1(6.3)
Oscillation angle(total)	degree	16°
Min. turning radius	mm(in)	2560(100.8)
Min. ground clearance	mm(in)	210(8.3)
STEERING		
Type	Center-Pivot frame articulation with full hydraulic power	
Angle	degree	40° on both sides
TRANSMISSION		
Type	Hydrostatic Transmission (H.S.T.)	
DRIVES		